

Paint

- X7 red
- TS26 white
- TS58 pearl blue
- XF1 flat black
- XF16 aluminium
- XF56 metallic grey
- X11 silver
- X10 gun metal
- X18 semigloss black
- X31 titanium gold

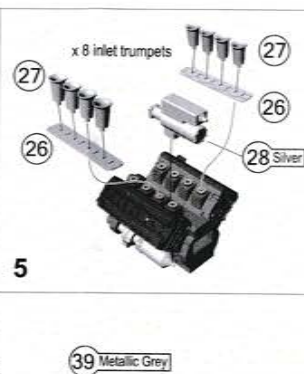

As at most events during 1972, Team Surtees entered 3 cars for the British Grand Prix at Brands Hatch, all carrying different sponsorships. Mike Hailwood was in his Brooke Bond Oxo car, Andrea de Adamich in the Ceramica Pagnossin liveried car and Tim Schenken drove the TS9B in the red and white colours of sponsor Flame Out. Schenken qualified in 5th position but retired from the race on lap 64 with a broken rear suspension. Schenken's car also carried the same livery at the French GP earlier in month.

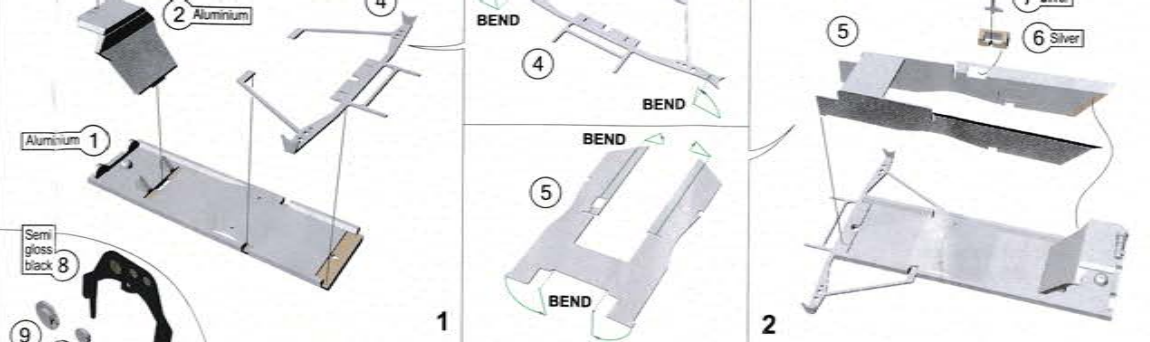
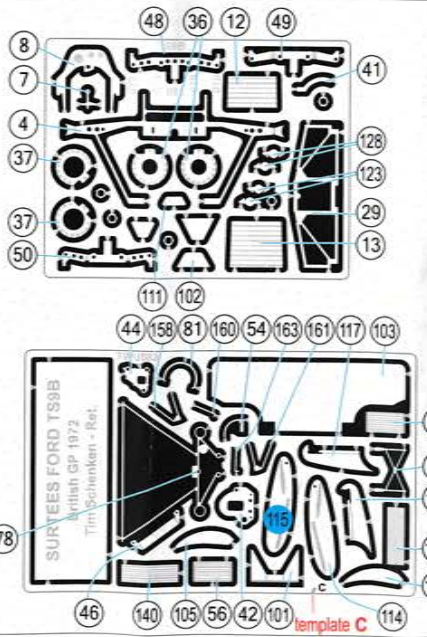
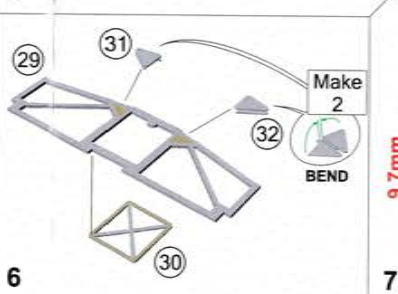

Photo Etch

