

TWU 057 Brabham BT33

1970 Monaco GP Jack Brabham- 2nd

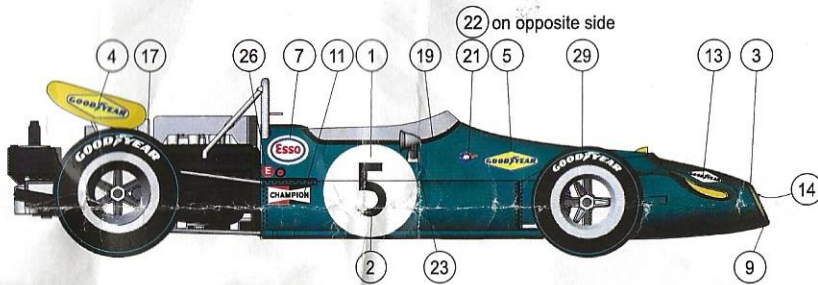
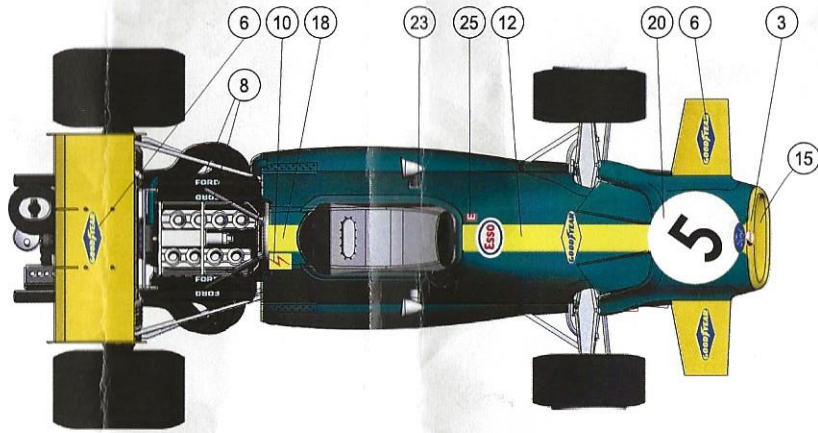

Decal Layout

Paint

- mix
- X2 white 8 parts
 - X4 blue 5 parts
 - X8 yellow 2 parts
 - X7 red
 - X8 yellow
 - X10 gun metal
 - X11 silver
 - X18 semi gloss black
 - XF1 flat black
 - XF2 flat white
 - XF8 flat blue
 - XF16 aluminium
 - XF56 metallic grey

For photo & decal references visit www.thiswayup.co.za

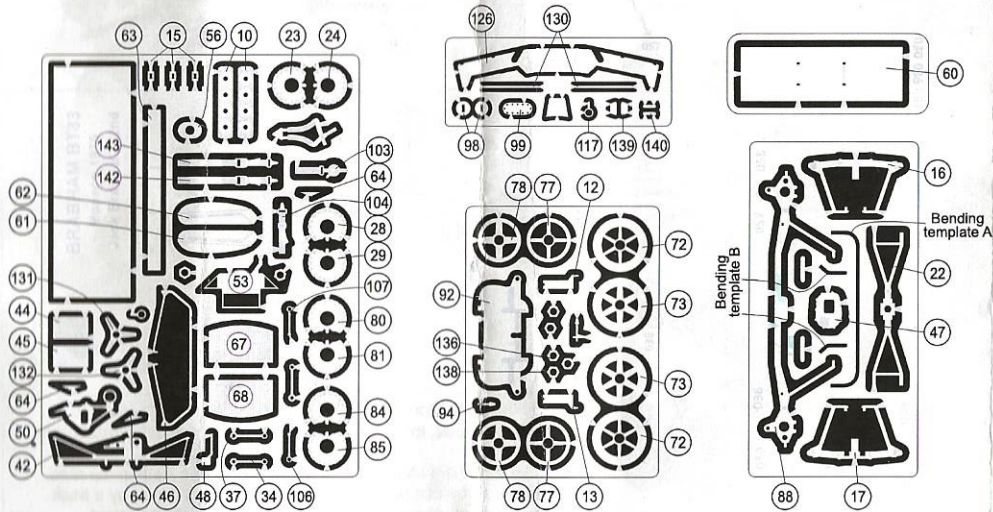

1

Drill ϕ 0.6mm

2

3

4

Note Position

5

use 0.5 wire for temporary location

6

7

8

9

10

11

12

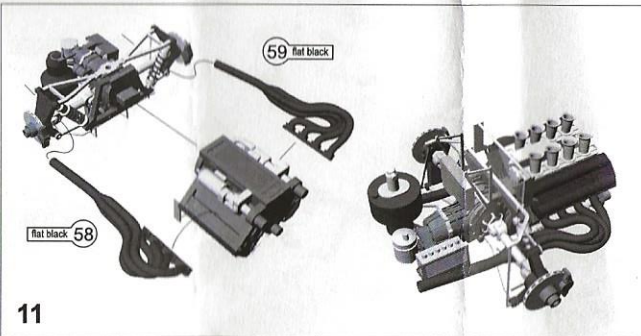

11

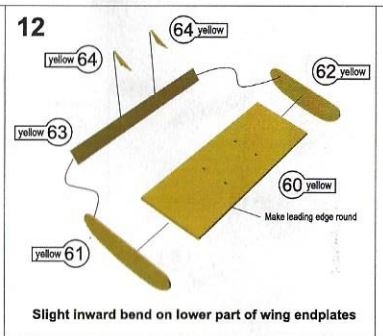

12

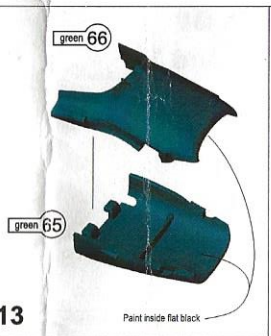

13

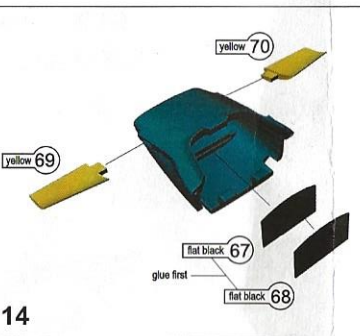

14

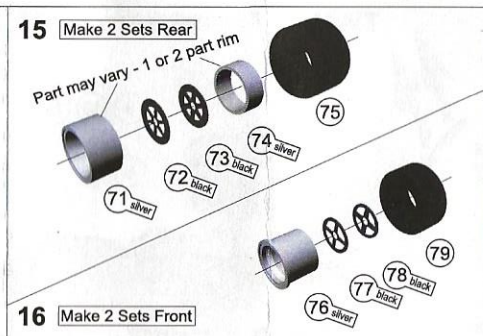

15

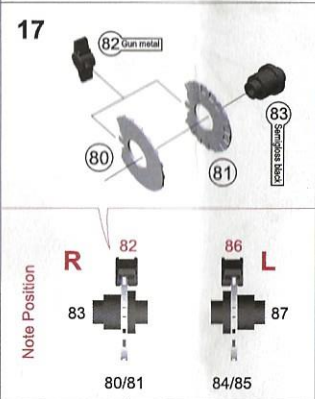

17

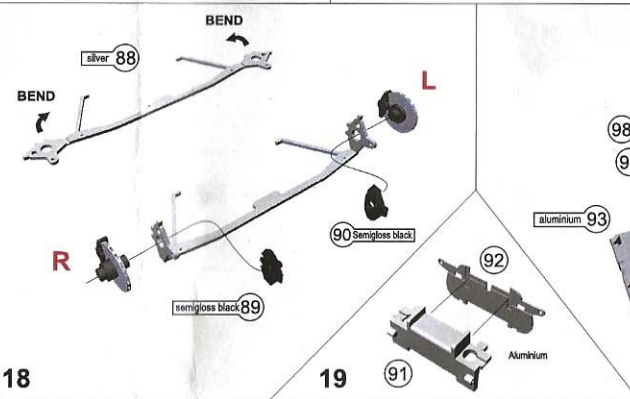

18

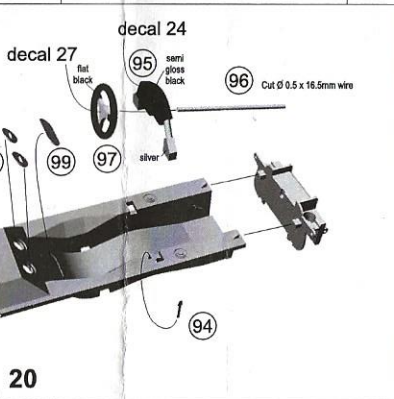

19

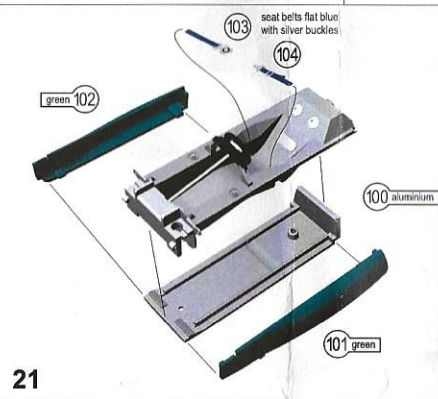

20

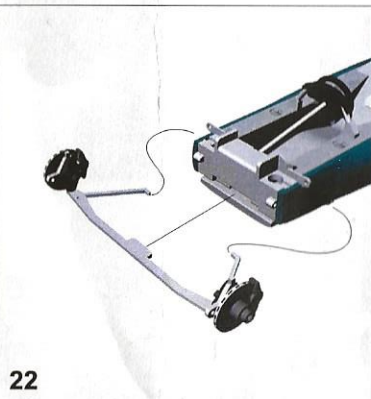

21

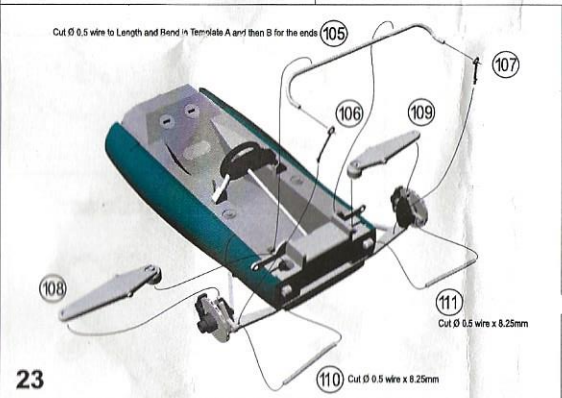

22

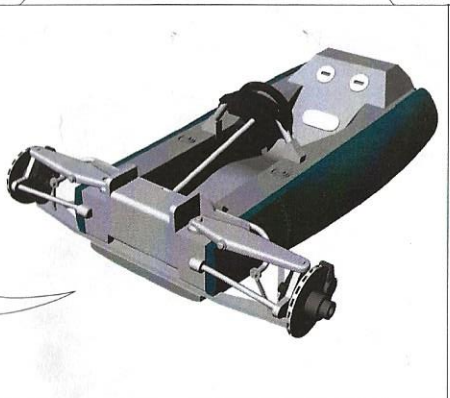

23

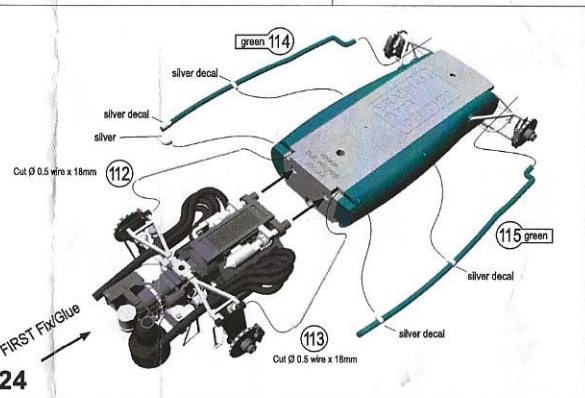

24

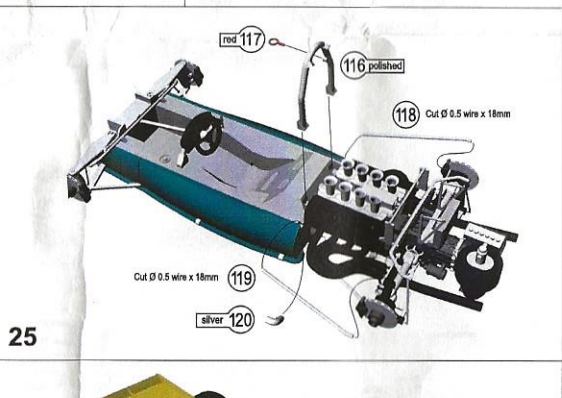

25

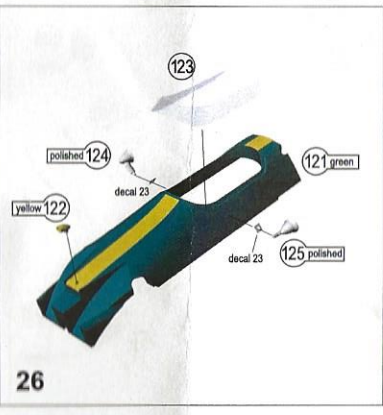

26

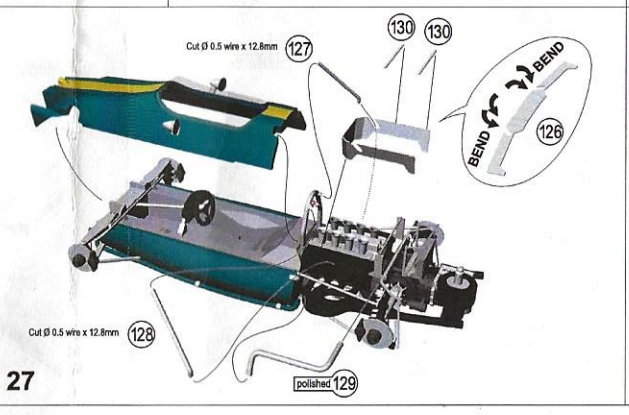

27

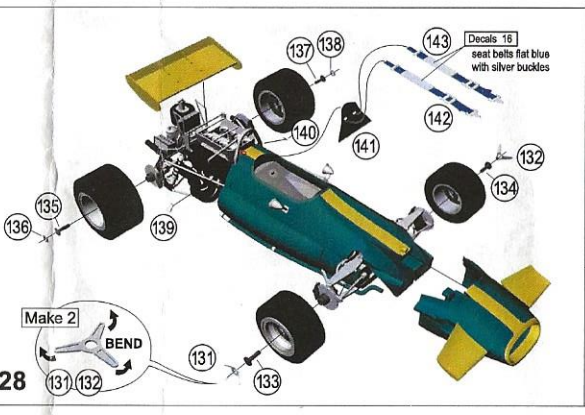

28

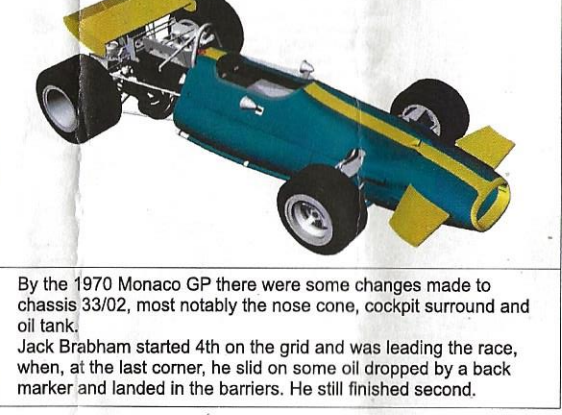

By the 1970 Monaco GP there were some changes made to chassis 33/02, most notably the nose cone, cockpit surround and oil tank. Jack Brabham started 4th on the grid and was leading the race, when, at the last corner, he slid on some oil dropped by a back marker and landed in the barriers. He still finished second.