

TWU039 Brabham-Ford BT33

1971 South African GP Dave Charlton - Retired

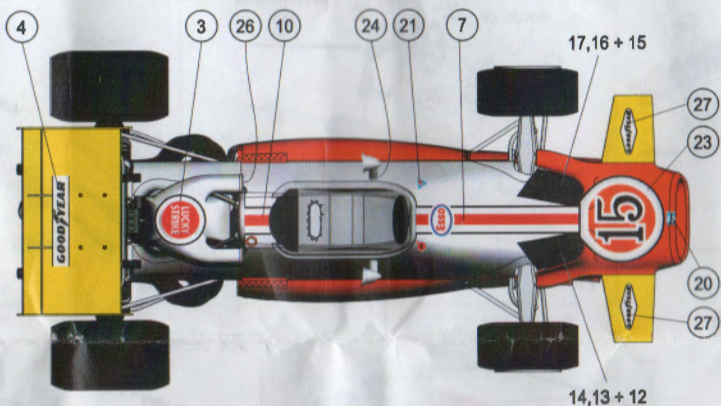
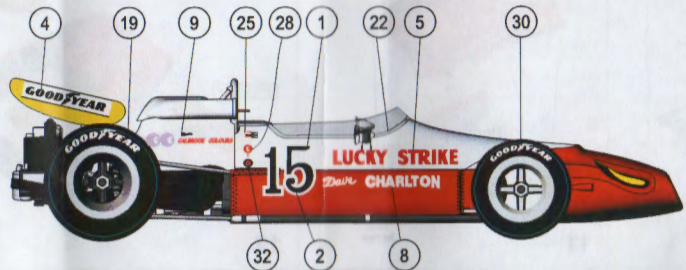

Decal Layout

For photo & decal references visit www.thiswayup.co.za

Paint

- TS26 white
- X7 red
- X8 yellow
- X10 gun metal
- X11 silver
- X18 semi gloss black
- XF1 flat black
- XF2 flat white
- XF8 flat blue
- XF16 aluminium
- XF56 metallic grey

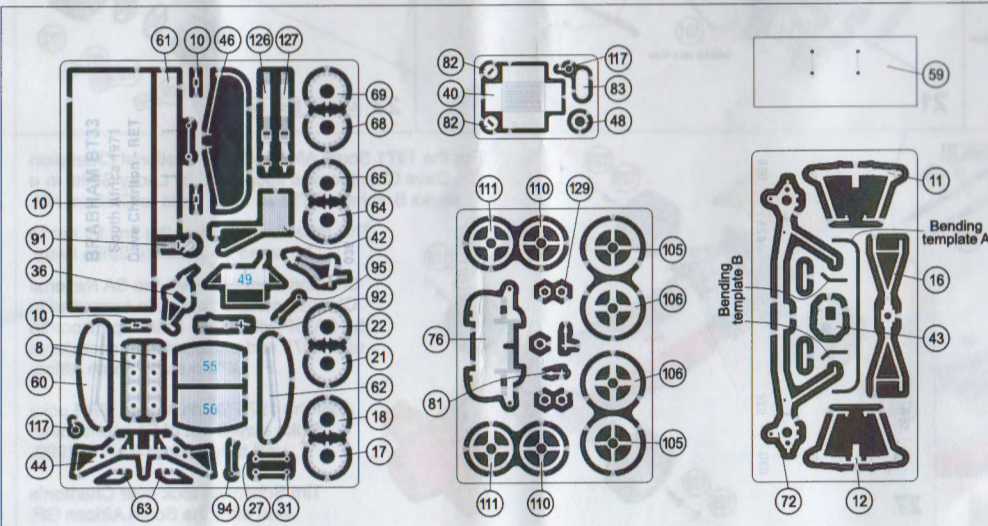

1

2

3

Note Position L R

4

Use 0.5 wire for temporary location

5

6

7

8

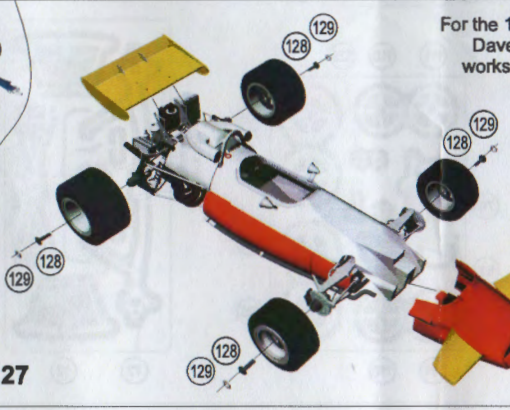
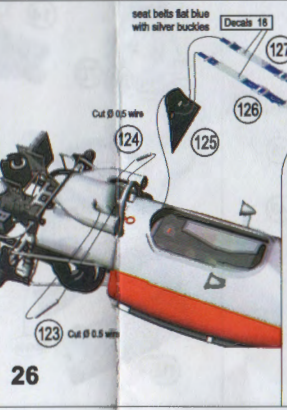
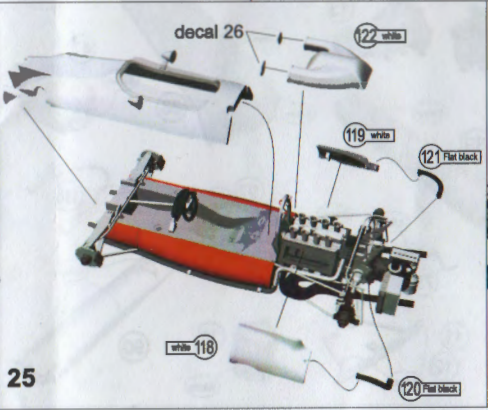
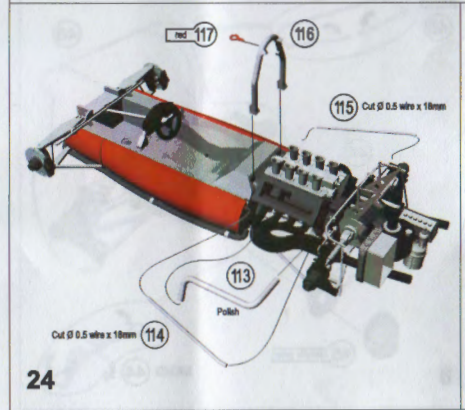
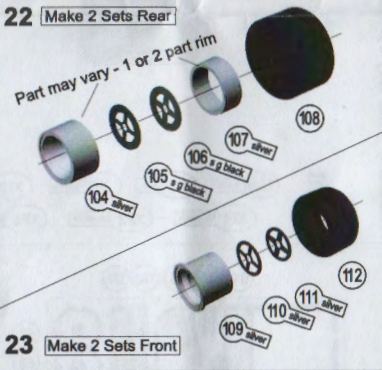
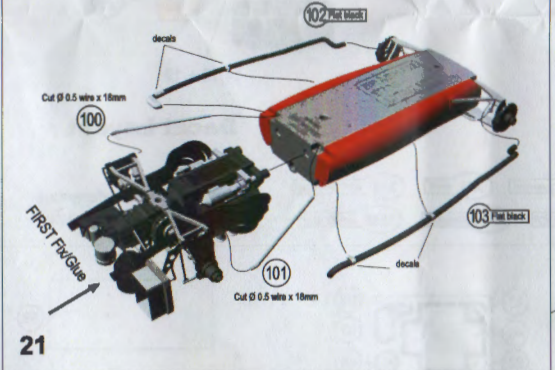
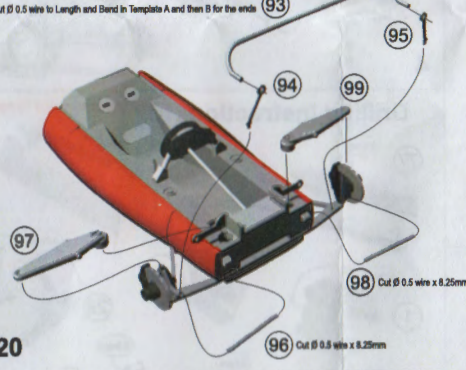
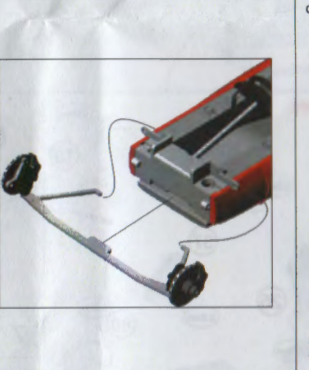
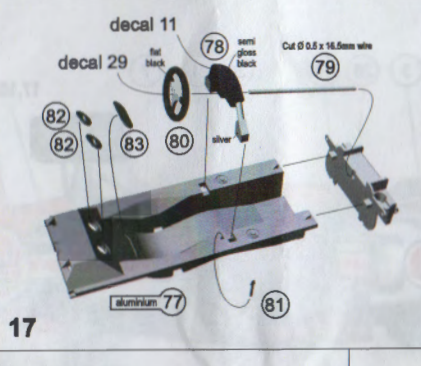
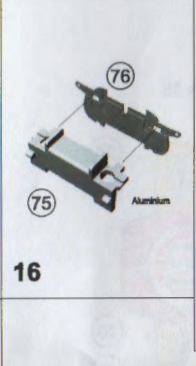
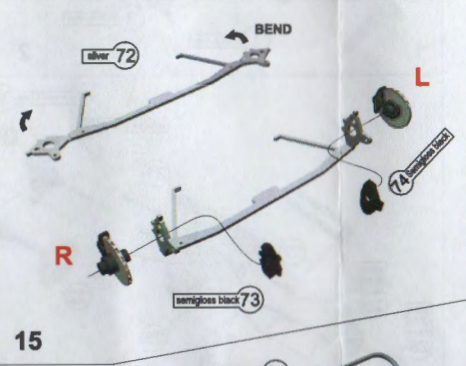
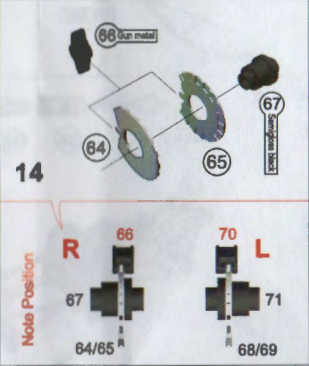
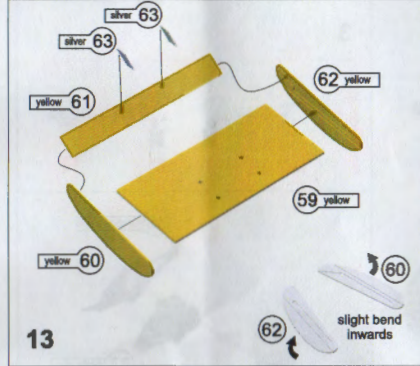
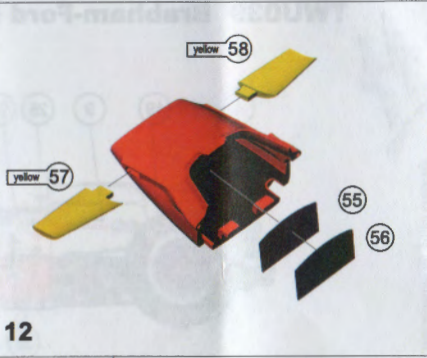
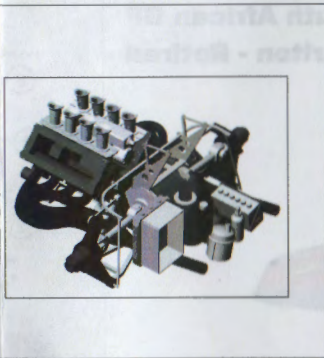
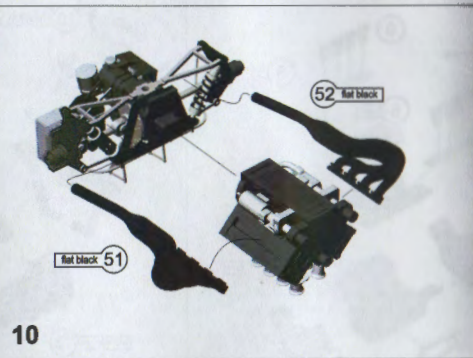
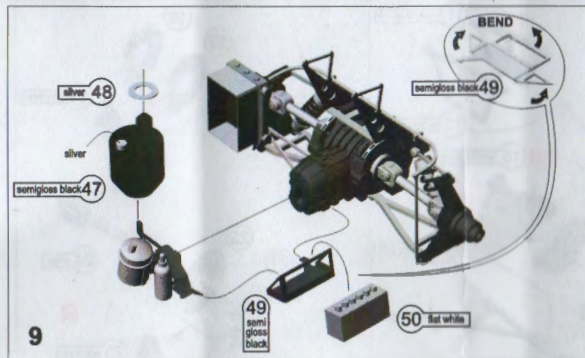

For the 1971 South African GP, SA National Champion Dave Charlton was sponsored by Lucky Strike in a works Brabham BT33 as team mate to Graham Hill.

This (chassis 33/3) was the first F1 car to be raced in full Lucky Strike livery.

Charlton went on to win the SA National Championship 5 times. He competed in the SA GP with Lucky Strike sponsorship until 1975 and participated in occasional F1 GP's outside South Africa.

After the 1975 South African GP, Lucky Strike stayed out of F1 sponsorship until they backed BAR in 1999.

Tim Schenken took over Charlton's seat after the South African GP.