

**JAPANESE G.P. 1991
SUZUKA**

**Ret. Andrea Zanardi
Ret. Andrea De Cesaris**

**N° 32 A. ZANARDI
N° 33 A. DE CESARIS**

**Zanardi : chassis 191/7
De Cesaris : chassis 191/1**

VERDE / GREEN.....	13-14-15-16-17-18- 19-20-21-22-23
NERO OPACO / MATT BLACK	1-2-7-8-24-25-26-27- 28-34-36-51
ARGENTO / SILVER.....	46-47-48-49-50
ROSSO / RED.....	29-30 (Zanardi)
VERDE CHIARO/ LIGHT GREEN.....	29-30 (De Cesaris)
BLU OPACO / MATT BLUE.....	35

CONVERSIONE COLORI / COLOURS CONVERSION

VERDE / GREEN

**Duplicolor Ford
Bitter Green**

Photo by PHOTO4

Viale C. Colombo, 36/38 - 17022 BORGIO VEREZZI (SV) ITALY - Tel. (019)615.250 / Fax (019)615.310

Made in Italy. Collector 1/43 Scale Models. Vietata la vendita ai minori di 14 anni. Nocivo per ingestione. Conservare fuori dalla portata dei bambini. Si declina ogni responsabilità per danni derivanti da uso improprio del prodotto.

Made in Italy. Collector 1/43 Scale Model. Not for sale to person under 14 years of age. Dangerous in swallowed. Keep out of the reach of children. Tameo shall not be held responsible for any damage or injuri resulting from improper use of the product.

Fabriqu e en Italie. Collector 1/43 Scale Model. Vente interdite aux enfants de mois de 14 ans. Dangereux si aval e. Conserver hors de la port ees des enfants. Tameo d elina toute r esponsabilit e dans le cas de dommages du pr ejudices d erivant de l'usage non appropri e du produit.

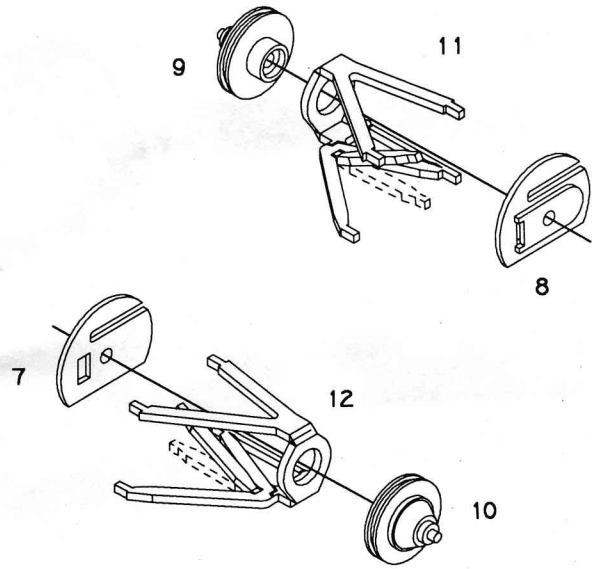
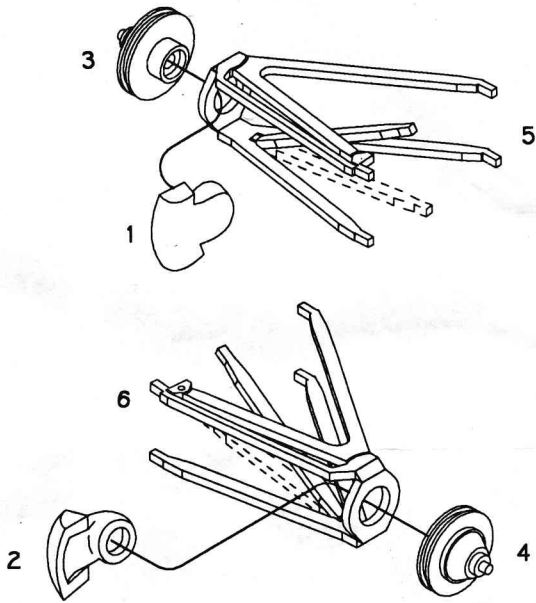
A**B**

COME PIEGARE LE SOSPENSIONI
HOW TO BEND SUSPENSIONS

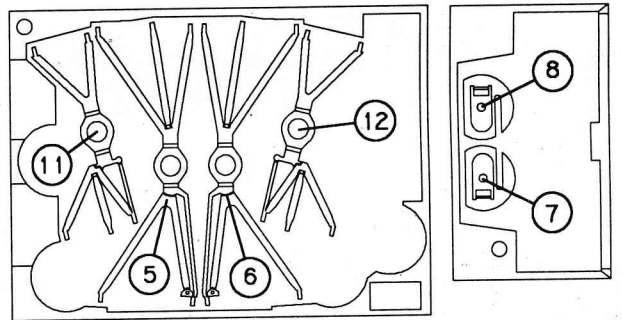
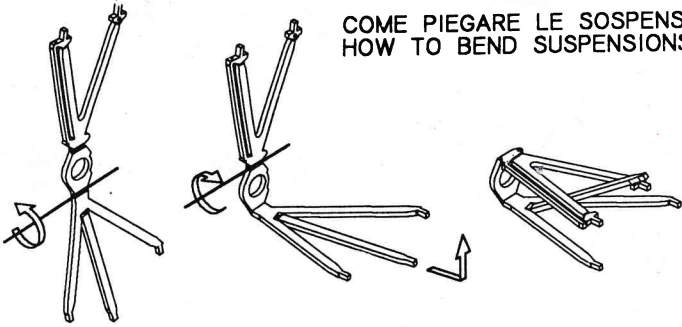

TMK 150

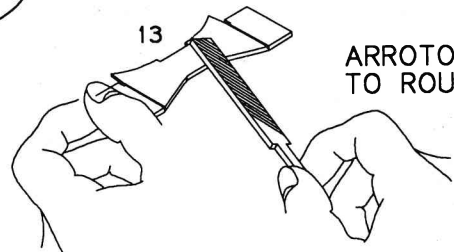
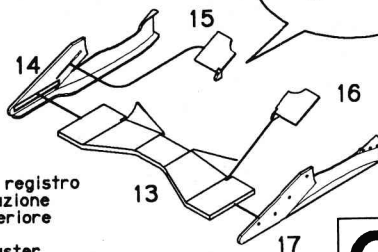
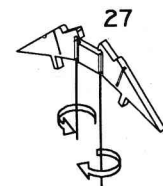
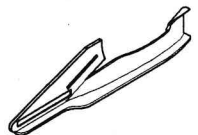
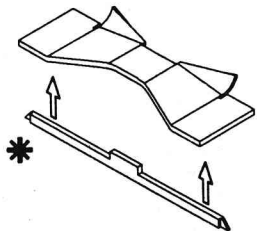
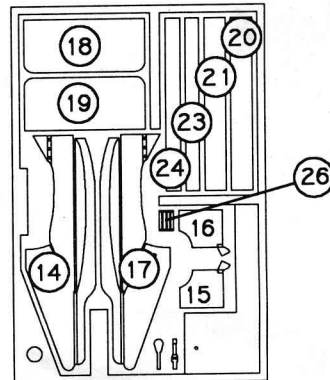
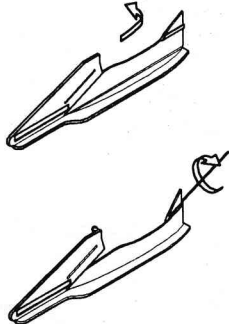
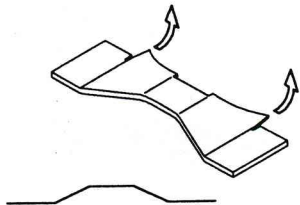
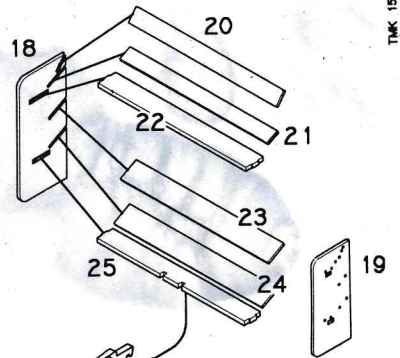
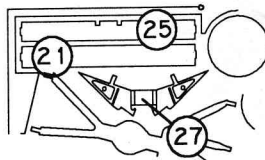
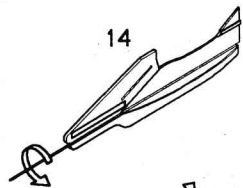
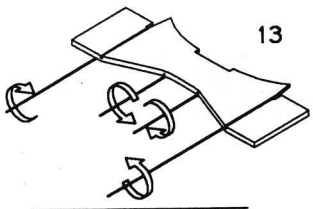

ARROTONDARE
TO ROUND OFF

* Usare come registro
per l'inclinazione
dell'ala anteriore

* Use this master
to bend the front wing

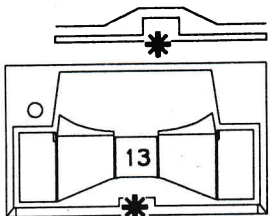
**C****D**

TMK 150

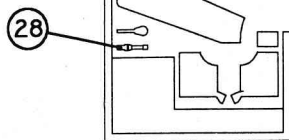
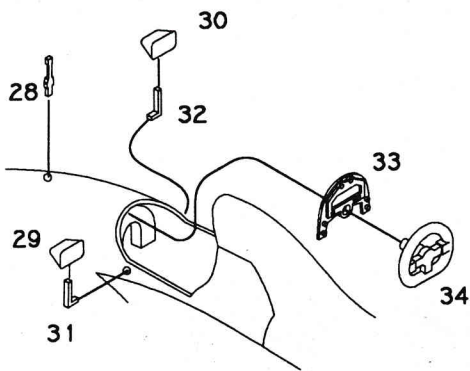

F

G

NERO OPACO
MATT BLACK

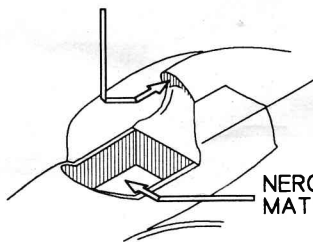

NERO OPACO
MATT BLACK

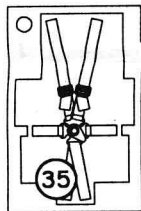

DECAL
WILLANS

DECAL
WILLANS

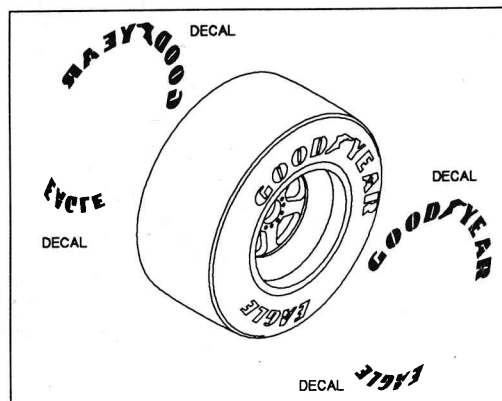
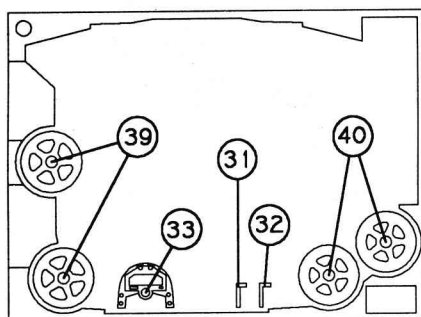
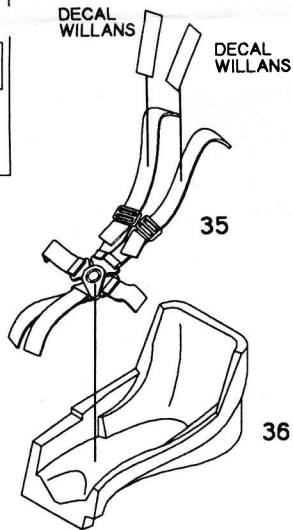

TMK 150

E

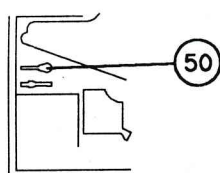

50

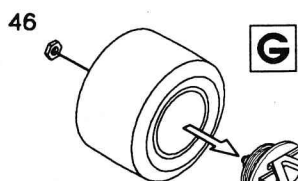

G

D

B

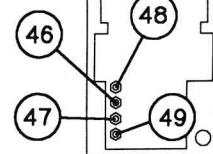

46

47

49

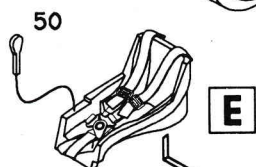

E

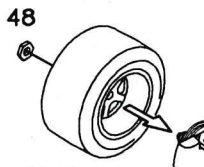

F

A

45

B

G

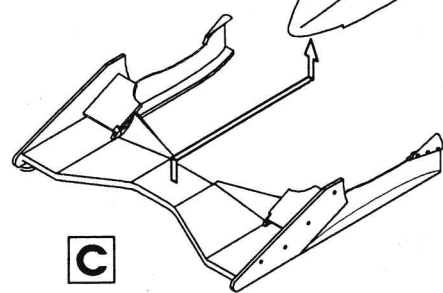

C

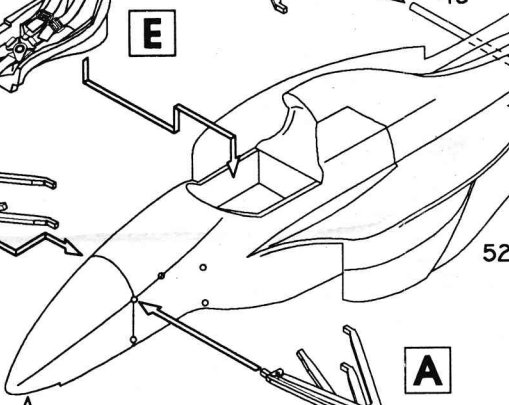

52

A

F



B

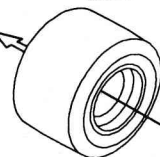

47

G

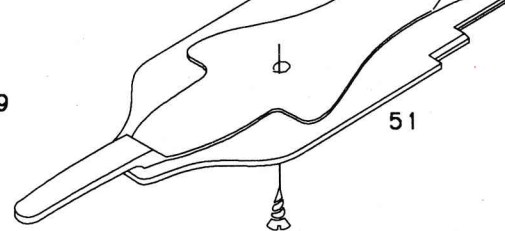

51

TMK 150

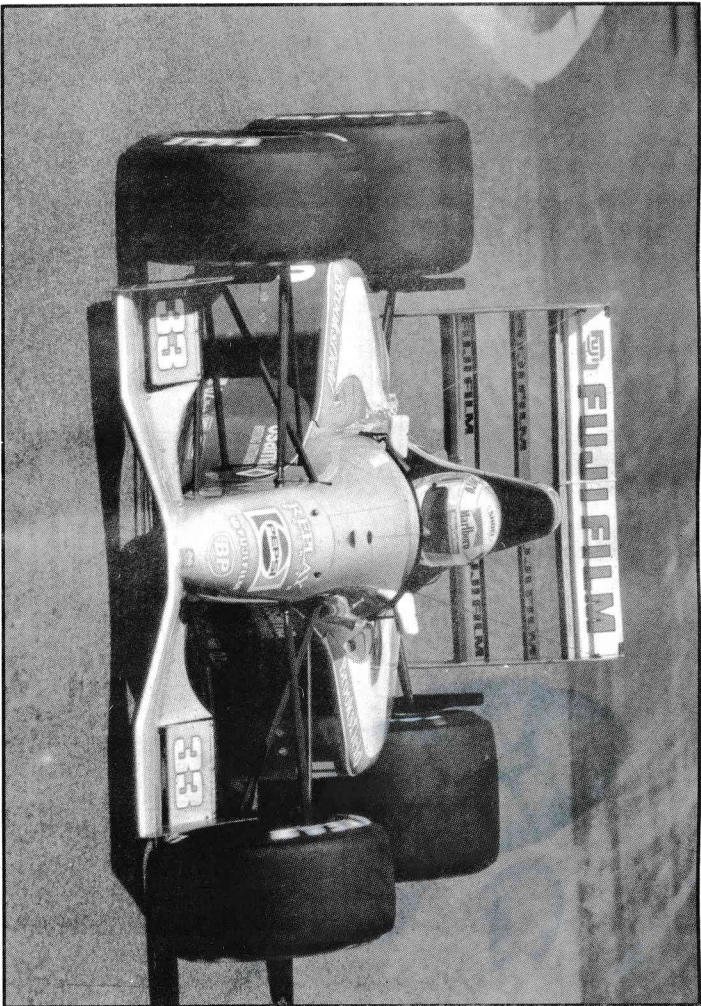

TMK 150

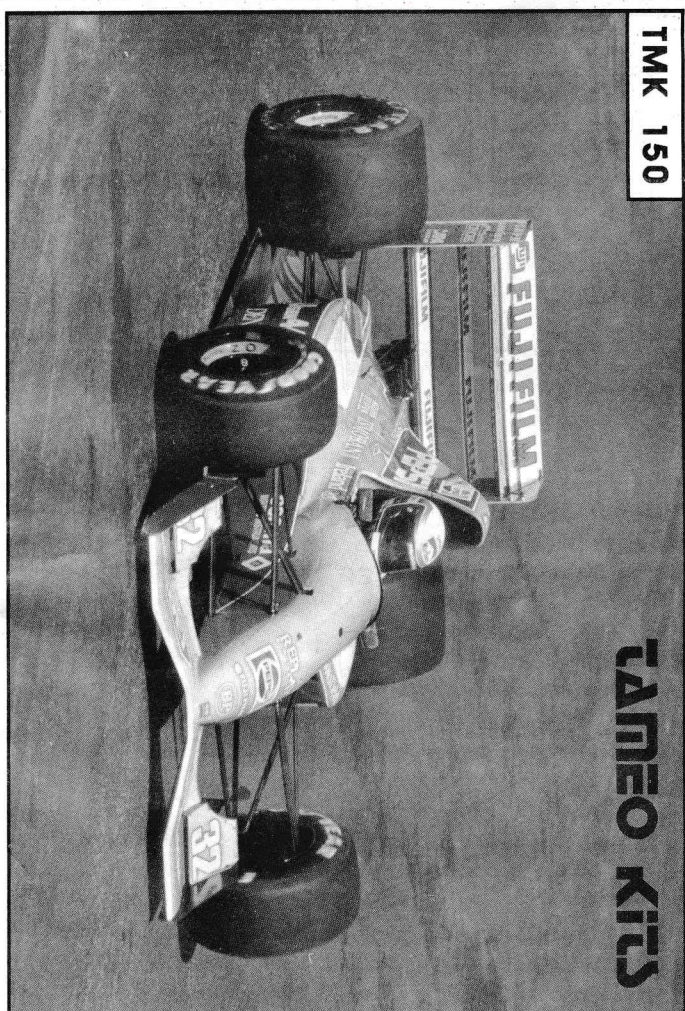

TAMEO KIZU

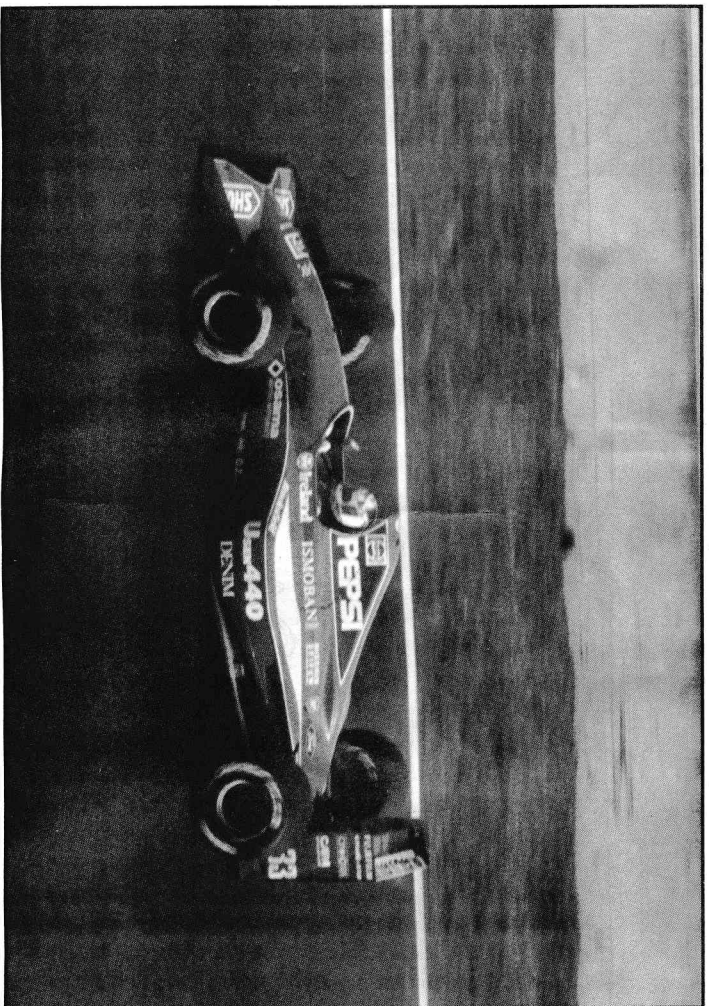

JORDAN 191 JAPANESE G.P. 1991

