

Williams FW07

Williams FW07 brought the Williams team its first pole (Jones) and its first victory Regazzoni at Silverstone 1979. A victory celebrated with orange juice. Followed by a 1-2 in Germany Jones 1st, 1st Austria (Jones) Regazzoni 5th, 1st Holland giving Jones three in a row. Jones and Regazzoni also had a 1-2 in Canada, but due to early season unreliability Ferrari won the Drivers Championship and the Constructors Cup. Reuteman joined Jones for the 1980 and Jones won the first race of 1980 in Argentina, the cars were then changed to FW07B SPEC and Jones went on to win the 1980 World Championship.

References:- Autocourse, Autosport File Williams and Williams story of a Racing Team by Bruce Grant- Brabham.

Building your 1/43rd Scale Racing Car.

Please check that all parts are present before removing any 'flash' left by the casting process with suitably shaped needle files and a modellers knife. It may be necessary to clear some locating holes with a small drill.

Referring to the drawings over leaf, test fit the parts together, trimming if required to ensure a perfect fit.

Any surface imperfections should be filled and castings carefully rubbed with wet-or-dry paper (No.600), used wet, before spraying the gloss finish. Paint the small parts with model enamel using our guide as a reference.

Use a quick setting epoxy adhesive to assemble the model taking care not to use too much. The transfers are waterslide type. Cut up the backing sheet before soaking in warm water to release them. Use a fine paint brush to pick up the small ones.

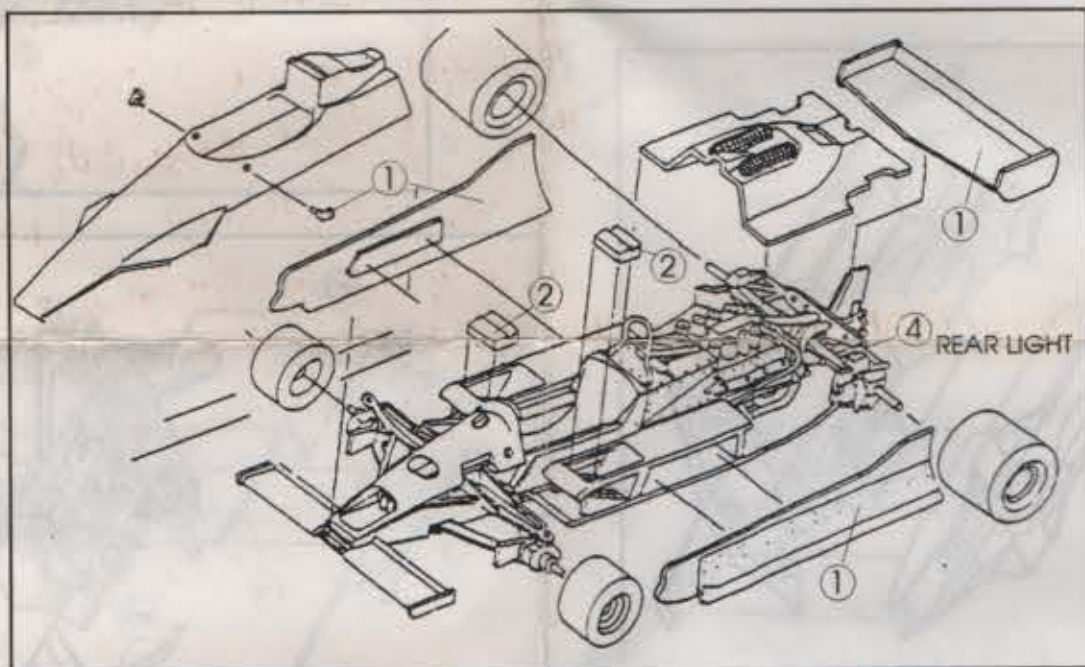

- 1 White
- 2 Polished Metal
- 3 Semi Gloss Black
- 4 Red
- 5 Gun Metal
- 6 Gloss Green
- 7 Gold
- 8 Silver
- 9 Dark Green
- 10 Mat Green
- Seat Belts Mat Lt. Blue with brass buckles

